



STERLING
TRUCKS

We Deliver

Distribution. It's a tough business, getting your load from point A to point B, and all the stops in between...on time. If it were easy, you wouldn't need a Sterling.

We build trucks that work. Tough, durable, reliable. Easy to operate and maintain.

Acterra, with a Class 5 – 8 rating, is a medium-duty truck designed for **best-in-class ride and handling**, maneuverability and toughness.

Acterra is suited to handle a range of Distribution applications: van, beverage, general delivery, bulk hauling or local moving.

A-Line over-the-road trucks and tractors **look as good as they work**...as tankers, as wholesale and retail delivery and private fleet vehicles.

They're now available with **performance improvements** designed to make them work even better:

- stronger/lighter-weight frames and more suspension choices;
- a re-designed cooling system;
- improved steering gear for tighter turning.

Sterling trucks...built to deliver.



General Specifications

BBC: Acterra: 106"; A-Line: 113"/122" **GVWR:** Acterra: 18,000 lbs. – 64,000 lbs.; A-Line: 60,000 lbs.

Engines:

- Mercedes-Benz:
MBE 900: (Acterra)
190-280 hp
MBE 4000: (A-Line)
350-450 hp
- Caterpillar:
C7/C9/C11/C13/C15:
190-330 hp (Acterra)
305-550 hp (A-Line)
- Cummins ISC:
225-350 hp (Acterra)
- Detroit Diesel Series 60:
350-500 hp (A-Line)

Transmissions:

- Manual:
• Eaton Fuller Direct Drive:
5-10-speed; Overdrive: 6-11-speed (Acterra)
7-15-speed; Overdrive: 10-18-speed (A-Line)
- Mercedes Direct Drive:
6-speed; Overdrive: 6-speed (Acterra)
- Automatic:
• Allison: 1000, 2000, 2400, 3000, 3200,
3500, MD, HD (Acterra), HD (A-Line)
- Eaton Fuller Autoshift: 6-10-speed (Acterra)
10-18-speed (A-Line)
- Meritor FreedomLine: 12-16-speed (A-Line)
- Ultrashift: 6-10-speed (Acterra)
10-speed (A-Line)

Axles:

- Front:
8k-18k (Acterra)
12k-14.7k (A-Line)
Meritor, Steertek
- Rear:
13k-46k (Acterra)
21k-46k (A-Line)
Meritor, Fabco

Suspensions:

- Front:
8k-18k (Acterra)
8k-14.6k (A-Line)
AirLiner™, Taper-leaf,
Multi-leaf, Flat-leaf
- Rear:
10k-46k (Acterra)
21k-46k (A-Line)
TufTrac® 2, Airliner™,
Taper-leaf, Multi-leaf,
Flat-leaf, Hendrickson

Because no two customers' operations are the same, Sterling offers extensive custom-engineered options and configurations. We engineer the right truck for your job, so you can get it done faster and easier.

Nothing works like a Sterling truck

Work hard. Ride easy.

For whatever line of work you're in, nothing works like a Sterling truck. It's tough and reliable on the job...easy on the driver. By design.

Driver Features:

Easy Cab Entry/Exit (Acterra shown)

- Full-length, low, two-step design is off-set like stairs for easy climbing.

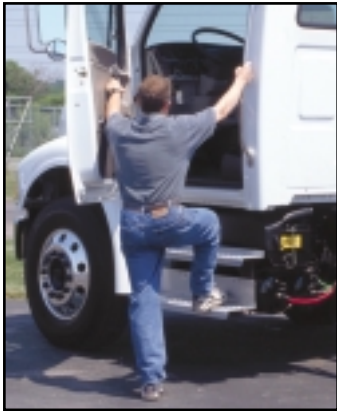

Tight Turning Radius (Acterra shown)

- An impressive wheel-cut angle results in a smaller turning radius for improved maneuverability.



Frames and Suspensions:

Lighter, Tougher Frames

- Extra-high tensile bolted 120,000 psi frames are stronger and lighter than previous offerings—with over 5 million RBM rating (A-Line) and up to 3.7 million RBM (Acterra).
- Optional premium HUCK® bolt fasteners enhance durability and eliminate retorquing in critical areas.

AirLiner™ Suspension

- 12k front/46k rear rating
- Premium cab comfort
- Helps protect cargo

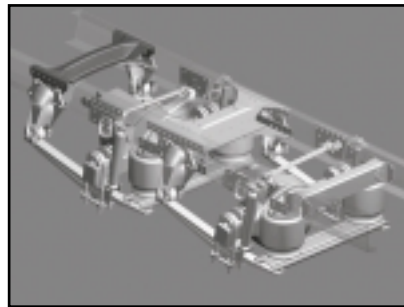

Component Locations:

Fuel Tanks

- Aluminum fuel tanks are mounted under-cab, for maximum ground clearance and a clean CA.
- Aluminum tanks have a 30% thicker wall than steel and are more corrosion-resistant.

Interiors:

Seat trims

- Base:
 - vinyl seats w/vinyl insert
- Optional:
 - vinyl seats w/cloth insert
 - cloth seats w/cloth insert
 - extra-tough Mordura seat covers (shown)



Several Seat Options:

Sterling EzyRider™

- Improves ride, comfort and stability.
- Adjustable firmness and lumbar support.
- Reduces fatigue.
- Convenient Seat Position Indicator.
- Air suspension options include heel protection, map pockets and arm rests.



Sterling Distribution

You'll like the way we work.™



For the Sterling Dealer nearest you, call 1-800-STL-HELP

www.sterlingtrucks.com

Some specifications and features shown or mentioned in this brochure are optional and are available on request at extra cost. Specifications are subject to change without notice. Sterling Trucks is registered to ISO 9001. Sterling Trucks, Willoughby, OH, 44094. Sterling Trucks is a member of the Freightliner Group. Copyright ©2003, Freightliner LLC. All rights reserved. Freightliner LLC is a DaimlerChrysler Company. Litho in U.S.A., MMS-55617, 09/03, **ST/MC-F-196**

AirLiner™, TufTrac® and Fleet Assistant® are trademarks of Freightliner LLC.